



Factory Interior Finishes

Ultra Coat and Ultra Stain

Nothing beats a factory finish applied with state-of-the-art equipment under rigorously controlled, ultra-clean conditions. Sierra Pacific's ever popular Ultra Coat and Ultra Stain* finishes definitely have you covered. These finishes are so tough, they resist scratching and marring, and so superior, they provide advanced protection against moisture. Better yet, once your windows and doors are installed there are no additional hassles like having to tape off, sand, prep, paint or seal the interior of your newly installed windows and doors.

When selected, these premium Ultra Coat and Ultra Stain finishes are applied to the visible interior wood surfaces of the unit. Taking it a step further, Sierra Pacific offers an **Ultra Coat Max** and **Ultra Stain Max** option available on any of our wood interior operating casement and awning windows, which will include the finishing of all wood surfaces visible from the exterior when the sash is in the open position. Talk about a small detail for added curb appeal!



*The Ultra Stain interior finish is currently not available on all product lines. Contact your SPW representatives for details.

Ultra Finish Options	
Ultra Coat	Ultra Coat Max**
Ultra Stain	Ultra Stain Max**
**Available on wood interior casement and awning windows only.	

Ultra Coat

White
Black

Ultra Stain

Clear
Espresso
Toffee

Custom color match available with both options

The Finishing Process

Sierra Pacific preps and finishes each wood component prior to window assembly, removing the additional steps of having to prep, sand, and finish an already assembled unit. So, once we assembled your finished interior unit, it's ready to ship!

Here are the steps in the process for each finish option:

ULTRA COAT (PAINT)
1. Light Sanding
2. Priming
3. Light Sanding
4. Topcoat (paint)

ULTRA STAIN
1. Light Sanding
2. Staining
3. Sealing
4. Light Sanding
5. Clear Coat

Maximize Your Finish

Ultra Coat Max and Ultra Stain Max will not only finish the wood surfaces as viewed from the interior, when the sash closed, but will also include the finishing of the wood surfaces as viewed from the exterior, when the sash is open.

Available on any wood interior operating casement or awning window, the Max finishing option will cover the backside surfaces of the interior wood stops so when the sash is open, no unfinished wood will be visible from the exterior.

Coverage Area

The below illustrations will highlight the wood surfaces finished when Ultra Coat, Ultra Stain, Ultra Coat Max, or Ultra Stain Max are selected.

Vertical Section Details

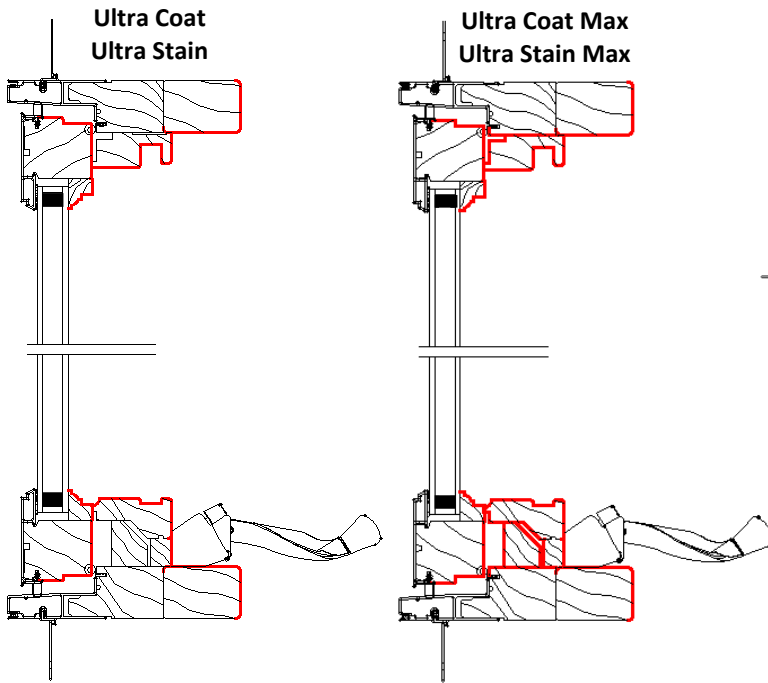

Horizontal Section Details

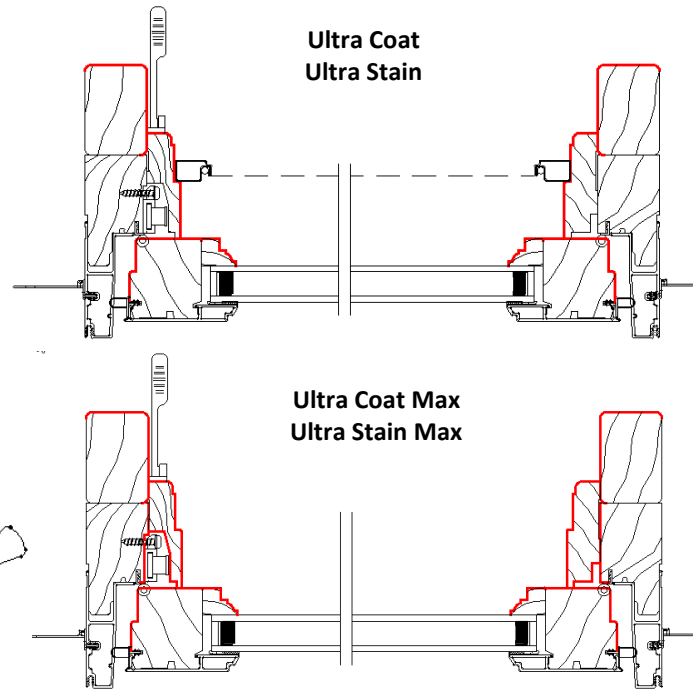

Primed and Ready

Planning on painting the interior of the unit on site? Choose our primed interior option, which similar to our Ultra finish process, we will prep and apply a white, water based prime coat to the interior wood components before assembly.

Planning on using a dark based paint color? Choose our black prime coat option to limit the number of coats needed for finishing.

Primed Interior Options

White

Black

Please contact your nearest Sierra Pacific Branch or Dealer location to see samples of our factory interior finish options on your choice of wood species. www.sierrapacificwindows.com/WhereToBuy

*Place Business Card or
Company Information Here*